



AK CRANE RANGE

FULLY FOLDABLE KNUCKLE AND TELESCOPIC BOOM TYPE

HS  **MARINE**

the ultimate crane specialist

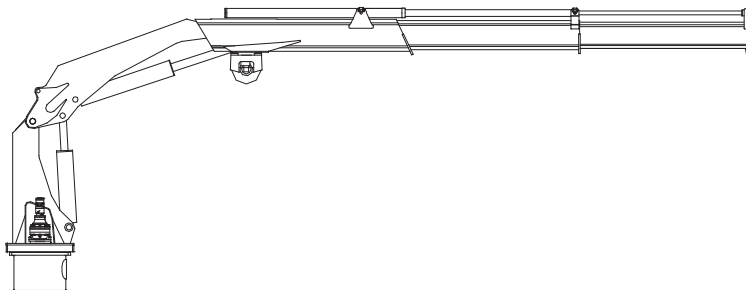



AK SERIES

Fully foldable knuckle and telescopic boom type cranes of different standard capacities.
 Custom built for operation to specific sea state conditions.

AK 13 HE1	Kg m	3190 3.13	1980 4.93	1345 6.93			
AK 13 LHE1	Kg m	3150 3.13	1860 5.18	1227 7.43			
AK 13 HE2	Kg m	3060 3.13	1875 4.99	1245 7.04	925 9.09		
AK 13 LHE2	Kg m	3025 3.13	1755 5.23	1125 7.53	820 9.83		
AK 13 HE3	Kg m	2795 3.08	1785 4.99	1145 7.04	830 9.05	645 11.15	
AK 13 HE4	Kg m	2795 3.08	1655 5.10	1030 7.15	718 9.15	543 11.23	440 13.29
AK 16 HE1	kg m	4070 3.13	2525 4.95	1725 6.95			
AK 16 LHE1	kg m	3965 3.13	2335 5.20	1550 7.45			
AK 16 HE2	kg m	3865 3.13	2355 5.00	1570 7.05	1170 9.10		
AK 16 LHE2	kg m	3825 3.13	2210 5.23	1425 7.53	1040 9.83		
AK 16 HE3	kg m	3770 3.13	2275 4.98	1480 7.03	1080 9.03	845 11.13	
AK 16 HE4	kg m	3600 3.07	2125 5.08	1350 7.13	955 9.14	730 11.22	595 13.28

AK 7 NE1	Kg m	2400 2.30	1345 4.10	900 5.90	
AK 7 NE2	Kg m	2305 2.30	1275 4.14	842 5.94	625 7.74
AK 10 NE1	Kg m	2660 3.00	1660 4.78	1115 6.78	
AK 10 LNE1	Kg m	2615 3.00	1545 5.03	1005 7.28	
AK 10 NE2	Kg m	2560 3.00	1575 4.84	1035 6.89	762 8.94
AK 10 LNE2	Kg m	2515 3.00	1470 5.09	932 7.39	675 9.69



AK 7





AK 16

AK 10



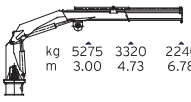
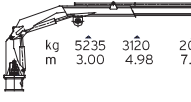
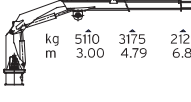
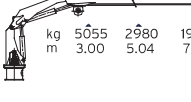
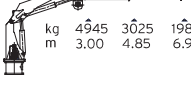
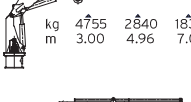
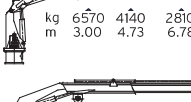
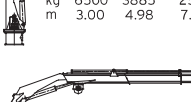
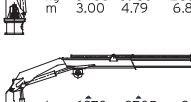
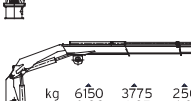
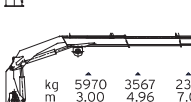
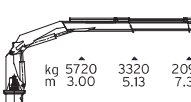



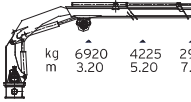
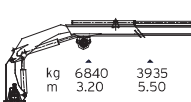
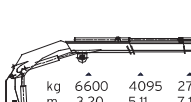
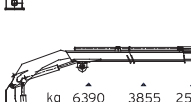
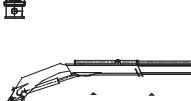
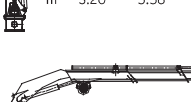
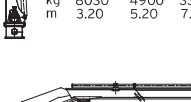
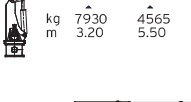
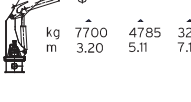
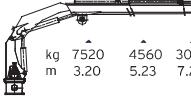
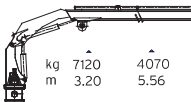

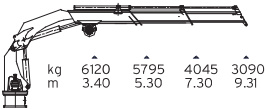
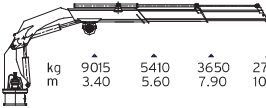
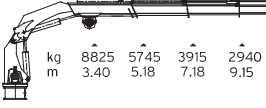
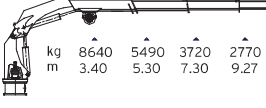
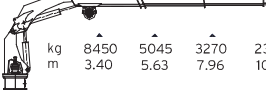
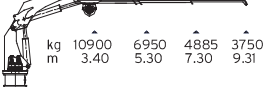
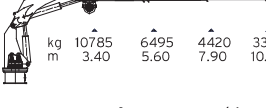
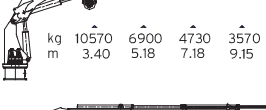

AK 13

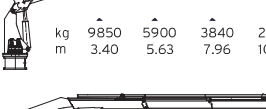
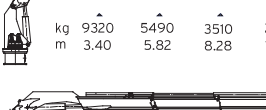
AK 20 E1		kg 5275 3320 2240 m 3.00 4.73 6.78
AK 20 LE1		kg 5235 3120 2055 m 3.00 4.98 7.28
AK 20 E2		kg 5110 3175 2120 1580 m 3.00 4.79 6.84 8.89
AK 20 LE2		kg 5055 2980 1930 1415 m 3.00 5.04 7.34 9.64
AK 20 E3		kg 4945 3025 1985 1460 1140 m 3.00 4.85 6.90 8.91 11.01
AK 20 E4		kg 4755 2840 1830 1315 1010 822 m 3.00 4.96 7.01 9.02 11.10 13.16
AK 25 HE1		kg 6570 4140 2810 m 3.00 4.73 6.78
AK 25 LHE1		kg 6500 3885 2570 m 3.00 4.98 7.28
AK 25 HE2		kg 6400 3980 2680 2005 m 3.00 4.79 6.84 8.89
AK 25 LHE2		kg 6270 3705 2425 1782 m 3.00 5.04 7.34 9.64
AK 25 HE3		kg 6150 3775 2500 1845 1450 m 3.00 4.85 6.90 8.91 11.01
AK 25 HE4		kg 5970 3567 2340 1700 1320 1080 m 3.00 4.96 7.01 9.02 11.10 13.16
AK 25/14 HE4		kg 5720 3320 2090 1490 1130 920 m 3.00 5.13 7.35 9.52 11.77 14.00

AK 30 HE2		kg 6920 4225 2920 2220 m 3.20 5.20 7.20 9.21
AK 30 LHE2		kg 6840 3935 2630 1950 m 3.20 5.50 7.80 10.11
AK 30 HE3		kg 6600 4095 2745 2040 1600 m 3.20 5.11 7.11 9.08 11.21
AK 30 HE4		kg 6390 3855 2555 1870 1450 1180 m 3.20 5.23 7.23 9.20 11.28 13.38
AK 30 LHE4		kg 6100 3460 2170 1530 1160 930 m 3.20 5.56 7.89 10.18 12.59 15.01
AK 34 HE2		kg 8030 4900 3395 2580 m 3.20 5.20 7.20 9.21
AK 34 LHE2		kg 7930 4565 3055 2280 m 3.20 5.50 7.80 10.11
AK 34 HE3		kg 7700 4785 3225 2405 1890 m 3.20 5.11 7.11 9.08 11.21
AK 34 HE4		kg 7520 4560 3050 2250 1755 1440 m 3.20 5.23 7.23 9.20 11.28 13.37
AK 34 LHE4		kg 7120 4070 2580 1830 1400 1130 m 3.20 5.56 7.88 10.18 12.59 15.01
AK 34/15.8 E4		kg 6930 3760 2350 1650 1250 1000 m 3.20 5.82 8.28 10.71 13.25 15.80

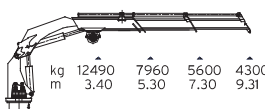
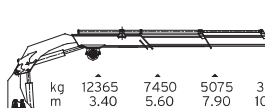
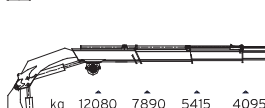

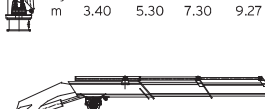
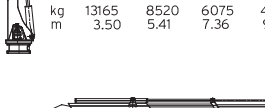
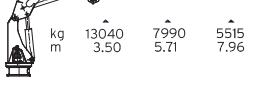
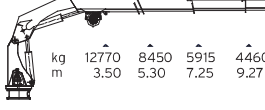
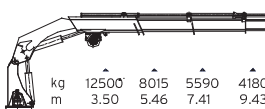
AK 40 E2		kg 6120 m 3.40	kg 5795 m 5.30	kg 4045 m 7.30	kg 3090 m 9.31			
AK 40 LE2		kg 9015 m 3.40	kg 5410 m 5.60	kg 3650 m 7.90	kg 2738 m 10.21			
AK 40 E3		kg 8825 m 3.40	kg 5745 m 5.18	kg 3915 m 7.18	kg 2940 m 9.15	kg 2320 m 11.28		
AK 40 E4		kg 8640 m 3.40	kg 5490 m 5.30	kg 3720 m 7.30	kg 2770 m 9.27	kg 2175 m 11.35	kg 1790 m 13.44	
AK 40 LE4		kg 8450 m 3.40	kg 5045 m 5.63	kg 3270 m 7.96	kg 2365 m 10.25	kg 1820 m 12.66	kg 1480 m 15.09	
AK 48 E2		kg 10900 m 3.40	kg 6950 m 5.30	kg 4885 m 7.30	kg 3750 m 9.31			
AK 48 LE2		kg 10785 m 3.40	kg 6495 m 5.60	kg 4420 m 7.90	kg 3335 m 10.21			
AK 48 E3		kg 10570 m 3.40	kg 6900 m 5.18	kg 4730 m 7.18	kg 3570 m 9.15	kg 2825 m 11.28		
AK 48 E4		kg 10340 m 3.40	kg 6590 m 5.30	kg 4495 m 7.30	kg 3370 m 9.27	kg 2655 m 11.35	kg 2190 m 13.44	
AK 48 LE4		kg 9850 m 3.40	kg 5900 m 5.63	kg 3840 m 7.96	kg 2780 m 10.25	kg 2140 m 12.66	kg 1750 m 15.09	
AK 48/15.8 E4		kg 9320 m 3.40	kg 5490 m 5.82	kg 3510 m 8.28	kg 2510 m 10.71	kg 1920 m 13.25	kg 1560 m 15.80	
AK 48/18.5 E5		kg 9000 m 3.40	kg 5170 m 5.96	kg 3250 m 8.42	kg 2270 m 10.85	kg 1690 m 13.39	kg 1330 m 15.95	kg 1100 m 18.55

AK 55 E2		kg 12490 m 3.40	kg 7960 m 5.30	kg 5600 m 7.30	kg 4300 m 9.31		
AK 55 LE2		kg 12365 m 3.40	kg 7450 m 5.60	kg 5075 m 7.90	kg 3830 m 10.21		
AK 55 E3		kg 12080 m 3.40	kg 7690 m 5.18	kg 5415 m 7.18	kg 4095 m 9.15	kg 3245 m 11.28	
AK 55 E4		kg 11850 m 3.40	kg 7550 m 5.30	kg 5160 m 7.30	kg 3875 m 9.27	kg 3055 m 11.35	kg 2525 m 13.45
AK 61 E2		kg 13165 m 3.50	kg 8520 m 5.41	kg 6075 m 7.36	kg 4640 m 9.42		
AK 61 LE2		kg 13040 m 3.50	kg 7990 m 5.71	kg 5515 m 7.96	kg 4135 m 10.32		
AK 61 E3		kg 12770 m 3.50	kg 8450 m 5.30	kg 5915 m 7.25	kg 4460 m 9.27	kg 3545 m 11.40	
AK 61 E4		kg 12500 m 3.50	kg 8015 m 5.46	kg 5590 m 7.41	kg 4180 m 9.43	kg 3310 m 11.51	kg 2730 m 13.62
AK 61 LE4		kg 12000 m 3.50	kg 7320 m 5.73	kg 4900 m 7.96	kg 3570 m 10.26	kg 2780 m 12.61	kg 2270 m 15.00
AK 61/19.5 E5		kg 6140 m 6.23	kg 3850 m 8.76	kg 2640 m 11.35	kg 1940 m 14.01	kg 1510 m 16.70	kg 1250 m 19.30



AK 40 AK 48



AK 50 AK 55



OPTIONAL SOLUTIONS

HS.Marine offer a wide range of optional solutions for the cranes. We are always available to discuss the technical specifications in order to find solutions that makes our cranes ideally suited for our customers' special application.

Some of the most common options are:

Hoisting winches

Including various type of pulley block, boom head, counter weight, hydraulic limit switch, electrical limit switch, load read out on winch, passive heave compensation, AOPS, MOPS, emergency drum release

Personnel lifting according to EN13852

Centralized greasing system

Flame metallization surface treatment

Various operator control positions

Separate control console, integrated seat or stand console, control support on column, cabin, radio remote control, cable remote control, remote seat chair control

Boom mounted led lights

Power packs for deck installation or for underdeck installation

Stainless steel cylinder rods or ceramic coated rods

Nuts, bolts and plastic caps and plugs for crane installation

Advanced safety system

Including HS.Marine Multifunction Service Unit and DiaMonD service software; local and remote operator screen with visualization of load, moment, message, warning and alarms

Sea state selector

Acoustic and visual alarm

Interface with other customer's equipment and remote emergency stop in category 2

Load radius indicator

Design approval, inspection during fabrication, witness of FAT by classification society, crane certification

Extra elements on distributor block with hydraulic activation till boom end for additional equipment

Low design temperature

Crane color

Crane adaptor for installation on existing basements

AK 67 E2	kg	14600	9455	6765	5180		
	m	3.50	5.41	7.36	9.42		
AK 67 LE2	kg	14500	8890	6160	4630		
	m	3.50	5.71	7.96	10.32		
AK 67 E3	kg	14205	9405	6610	5000	3980	
	m	3.50	5.30	7.25	9.27	11.40	
AK 67 E4	kg	13950	8955	6275	4720	3745	3095
	m	3.50	5.46	7.41	9.43	11.51	13.62
AK 72 E2	kg	15835	10255	7345	5625		
	m	3.50	5.41	7.36	9.42		
AK 72 LE2	kg	15690	9620	6680	5025		
	m	3.50	5.71	7.96	10.32		
AK 72 E3	kg	15240	10090	7070	5345	4245	
	m	3.50	5.30	7.25	9.27	11.40	
AK 72 E4	kg	14925	9580	6695	5025	3980	3290
	m	3.50	5.46	7.41	9.43	11.51	13.62
AK 72/16 E4	kg		8410	5520	3970	3060	2490
	m		5.86	8.23	10.66	13.16	15.69



AK 67

AK 61

AK 72



QUALITY SOLUTIONS / QUALITY DETAILS

MARINE DESIGN

Our cranes design has been specially developed and improved for operation in marine environment. All structures have been designed to take up heavy lateral forces and to have a low value of elastic deflection during loading. All parts have been designed and protected for easy maintenance.

DESIGNED FOR LONG LIFE

Each crane components and each crane parts are selected and designed for long life. We totally understand what downtime means in marine business and the impact of service costs. Our goal is the reliability of the crane therefore we only use components or technical solutions of proven long lifespan.

CRANES WITHOUT LIMITATIONS

Our cranes can work in any configurations: no matter if the boom is fully vertical extended up or if it is knuckled downwards. The safe working load can be moved by any crane cylinders, including the telescopic ones.

TRANSPORT STEEL FRAME

Together with the cranes, we include a suitable transport frame made in steel. The transport frames are suitable for handling by forklift and offer extra protection and easier handling for safe delivery to customer.

EASY AND TESTED INSTALLATION

HS.Marine guarantees easy installation of all cranes. All the cranes connection points are properly prepared and clearly marked in order to make the installation as easy as possible. We always prepare the specific interface with customer's system and we test the crane with such interface before delivery.

LARGER PINS

In comparison to other cranes, the articulation points of our cranes are most likely bigger. We always calculate and design the cranes to withstand side loads. This results in larger pins.



POWERFUL SLEWING

To guarantee higher rotation torque capability, all HS.Marine cranes are provided with slew bearings and powerful and precise gearboxes.

All HS.Marine cranes can be supplied for continuous unlimited slewing.

EXCEPTIONAL STRENGTH AND LOW FLEXION

CRANE DESIGN BASED ON RELIABILITY

We focus on quality solutions and quality of the components.

CRANE BOOM TELESCOPIC SEQUENCE

As a befitting safety issue, we underline that the crane booms respects the telescopic sequence during extension out and retraction.

STAINLESS STEEL CONTROL POSITIONS

Control position are in stainless steel and have high protection from water spray

HIGH ATTENTION TO DETAIL

For the best reliability and for easy maintenance.

SALT PROOF SEALING

We do our utmost to completely seal any exposed opening, such as the surface between two flanges, pins, plugs, umbraco bolts hearts, cylinder plugs, access holes for maintenance etc.

SURFACE TREATMENT GIVING A LONGER LIFE

Our design, our material and component selection, our excellent surface treatment and painting procedures and our salt proof sealing, all guarantee a strong barrier against corrosion.



DETAIL PROTECTION

All components are individually painted before assembling.

TAGGING

Cable, hose and components are tagged with the spare parts code.

FULLY TESTED

All our cranes are always load tested at the factory prior to delivering to our customers.

CUSTOMER SERVICE

None of our customers are left alone.

We have a global service network. We care about our customers.

AS BUILT DOCUMENTATION

All provided documentation is as built, extensive and specially prepared for each individual crane.

Each manual states the crane serial number and shows actual photographs taken of the crane and its many details.





HS MARINE

HS.Marine has a wide range of **fully foldable knuckle and telescopic boom cranes**, for low deck space occupation and very compact recovering.

All model can be heavily customized versions according to the customers' special applications.

All cranes have been designed and built from the ground up for marine use and are successfully utilized in the most critical application demonstrating reliability.

HS.Marine cranes are designed and built to last.

Low and easy maintenance, reduced spare parts consumption, smaller crane down time and significantly longer time make HS.Marine the best value money can buy.

The marine environment demands equipment of the highest level of quality to ensure reliable and safe operations: HS.Marine cranes are able to satisfy these requirements.

Through experience, service commitment and global presence we provide the best cranes and life cycle support.

HS.MARINE THE QUALITY SOLUTION

HS.Marine range include stiff boom, telescopic boom, knuckle boom and knuckle telescopic boom cranes.



FOLDABLE KNUCKLE & TELESCOPIC



KNUCKLE & TELESCOPIC



KNUCKLE BOOM



TELESCOPIC BOOM



STIFF BOOM



HS.MARINE Srl
Via delle Querce, 1/3
46019 Viadana (MN)
ITALY

VAT No. IT02025300209
+39 0375 25 48 19
info@hsmarine.net
www.hsmarine.net

